



UNITED STATES MARINE CORPS
MARINE CORPS INSTALLATIONS EAST-MARINE CORPS BASE
PSC BOX 20005
CAMP LEJEUNE NC 28542-0005

5090.20.1
G-F/BEMD
26 Aug 24

Mr. Michael Montabello
NC Division of Water Resources
NPDES Compliance and Expedited
NPDES Permit Unit
1617 Mail Service Center
Raleigh, NC 27699-1617

Dear Mr. Montabello:

To comply with House Bill 1160 of the Clean Water Act of 1999, Marine Corps Base Camp Lejeune (MCB CAMLEJ) is providing the public with an annual report that summarizes its collection system's performance. Enclosure (1) is the July 2023 through June 2024 Camp Lejeune Advanced Wastewater Treatment Plant System and Wastewater Collection System Performance Report. This letter certifies that the report is accurate and complete.

The report was distributed via the Base Facebook and Twitter sites (which also cover Marine Corps Air Station New River), Base Housing e-mail, and Base Wide Area Network (WAN) Mail notifying residents of the availability of the report. The report document is available on the Camp Lejeune website:

<http://www.lejeune.marines.mil/OfficesStaff/EnvironmentalMgmt/AnnualReports/>

If you require additional information or need clarification of the information provided, please contact Mr. Travis Voorhees, Environmental Quality Branch, Environmental Management Division, G-F, at (910)451-9518.

Sincerely,

LOWDER.ROBERT
.A.1074303303

Digitally signed by
LOWDER.ROBERT.A.1074303303
Date: 2024.08.26 09:17:04 -04'00'

ROBERT A. LOWDER, P.E.
Director, Environmental Management
By direction of
the Commander

Enclosure: 1. 2023-2024 Camp Lejeune Advanced Wastewater Treatment Plant System and Wastewater Collection System Performance Report (1 copy)

Copy to:
ODI (File# 28296)
Steven Whited

Marine Corps Base Camp Lejeune

Advanced Wastewater Treatment Plant

Permit No. NC0063029

Wastewater Collection System

Permit No. WQCS00015

Annual Performance Report

July 2023 - June 2024



Terms and Definitions

mg/L (milligrams/Liter) - the units of concentration used to express environmental measurements.

1 mg/L is equivalent to 1 part per million. You can think of 1 ppm as 1 cent in \$10,000.

Influent - wastewater entering the treatment plant

Effluent - treated water leaving the treatment plant

BOD (Biochemical Oxygen Demand) - is a pollution indicator. It is a measurement of the dissolved oxygen needed by microorganisms to biologically degrade pollutants. The normal BOD test is conducted during a 5 day laboratory period and denoted BOD₅. Raw domestic sewage typically has a BOD₅ of about 200 mg/L whereas a typical BOD₅ of unpolluted surface water would be less than 5 mg/L. If discharged to the environment, water with an elevated BOD could deplete (use up) the dissolved oxygen in rivers and streams due to the biological degradation of the pollutants by naturally occurring microorganisms. This can cause fish kills and septic conditions.

TSS (Total Suspended Solids) - is a pollution indicator. It is simply a measurement of undissolved solids. Similar to BOD, raw domestic sewage typically has a TSS of about 200 mg/L. If discharged to the environment, elevated levels of TSS can produce sludge deposits and cause septic conditions.

Ammonia Nitrogen (NH₃-N) - represents the concentration of nitrogen bound in the ammonia form. Raw domestic sewage typically has an NH₃-N of about 15 to 20 mg/L. If discharged to the environment, elevated levels of NH₃-N can cause three problems. These include: (1) depletion of dissolved oxygen in rivers and streams because the biological degradation of ammonia is an oxygen consuming process, (2) impairment and death to fish and other aquatic organisms due to the direct toxicity of ammonia, and (3) increased growth of algae due to the nutrient effects of nitrogen.

Phosphorous - is an essential nutrient for all biological growth. However, if discharged to the environment, elevated levels can cause excessive growth of algae and other aquatic plants. The subsequent decay of these plants can result in a depletion of dissolved oxygen.

Treatment Plant Diagram

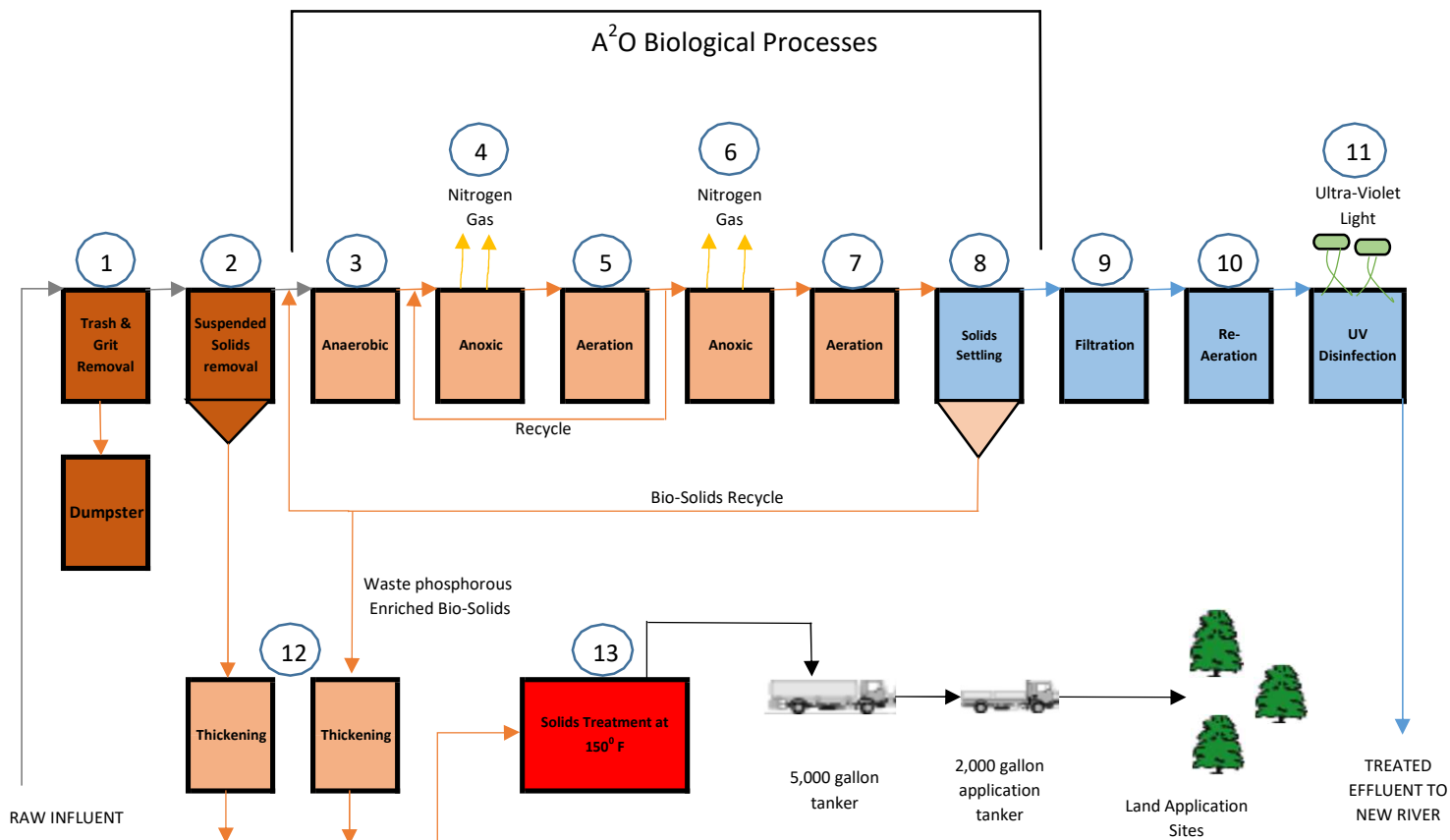

GENERALIZED WASTEWATER TREATMENT PLANT (WWTP) PROCESS DESCRIPTION

The Camp Lejeune Advanced Wastewater Treatment Plant (AWWTP) is an advanced biological process that consists of three different microbial environments. The combined environments are called the A2O process for Anaerobic, Anoxic and Oxidic. These three zones cultivate a special mix of beneficial microorganisms that absorb phosphorous and convert chemically bound nitrogen to harmless and inert nitrogen gas. Residual phosphorous not absorbed by the microorganisms is removed by chemicals added by the WWTP's operations staff. Other microorganisms (primarily in the oxidic zone) degrade wastewater pollutants by using organic material as food and converting it to new microbes, carbon dioxide and water. All of the three A2O zones consist of mixed slurries of wastewater and microorganisms. After treatment, the water and microbes are separated by gravity settling in large tanks. The clean water is skimmed from the surface, filtered, disinfected with ultra-violet light and returned to the New River. The microbes are continuously collected from the bottom of the tanks and returned to the three A2O zones using recycle pumping systems. This recycling provides a continuous source of microbes to degrade incoming pollutants. As pollutants are removed, the microorganisms grow and multiply. This growth results in the production of excess microorganisms. These excess microbes are continuously removed in a process called wasting to maintain a consistent and optimal balance between available microbes and the amount of food (pollutants) entering the WWTP. The excess microorganisms (called residuals or biosolids) are treated at an elevated temperature (+/- 150° F) to kill disease-causing organisms, to reduce odors, and for further treatment of biodegradable pollutants. The treated residuals are applied to agriculture and forested areas for their beneficial nutrients and soil conditioning characteristics. The flow of water into and out of the WWTP is a continuous operation - the WWTP operates 24 hours per day and 365 days per year.

Descriptions of the WWTP processes are summarized below:

1 - Preliminary Treatment is merely a screening process that removes large, inorganic debris such as sticks, rags, grit and sand. The removal of these constituents protects downstream equipment.

2 - Primary Clarification consists of large tanks where suspended solids settle to the bottom. The settled solids are transferred to the solids treatment process. In general, this process removes about 50% of the TSS entering the WWTP influent. The remaining fraction is either degraded (solubilized) in the biological processes or removed in the WWTP's secondary clarifier.

3 - The Anaerobic Zone is a mixed tank void of dissolved oxygen. The absence of all oxygen is conducive to the growth of special bacteria (*Acinetobacter*) that consume organic acids and release stored phosphorous in the anaerobic tank. However, these same organisms uptake high levels of phosphorous when they enter the aerobic (oxidic) zone of the WWTP. Thus, the cycling of the microbes between the anaerobic and oxidic environments is the mechanism responsible for enhanced phosphorous uptake. This cycling is accomplished by the normal flow of water and the recycle system that returns the microbes to the anaerobic zone after they have been oxygenated in the oxidic zone of the WWTP. Phosphorous (an algae causing nutrient) is ultimately removed from the WWTP by wasting excess microbes after the oxygenated cycle and when stored phosphorous levels are greatest.

4 - The Anoxic Zone consists of mixed tanks that have essentially no dissolved oxygen. However, these tanks do contain oxygen that is chemically bound to nitrogen in a molecule called nitrate ($\text{NO}_3\text{-N}$). This nitrate nitrogen is a by-product from the biological treatment of ammonia and is introduced to the anoxic zone through the recycle from the outlet of the aeration tank. In the absence of dissolved oxygen, bacteria in the anoxic zone break the chemical bond between the oxygen and nitrogen. The oxygen is used by the microbes to produce new bacteria, water and carbon dioxide. More importantly, the nitrogen (a nutrient responsible for the growth of excess algae) is removed from the water and is released to the atmosphere as a harmless and inert gas.

5 - The Oxidic (Aerobic) Zone consists of mixed and oxygenated tanks. Oxygen is supplied from the atmosphere using mechanical agitators located on the surface of the tanks. In this process, aerobic (oxygen using) and other microorganisms perform the following:

Reduce BOD: This is the biological degradation of wastewater pollutants. Simply stated, microorganisms consume organic material for food and convert it to new microbes, carbon dioxide and water.

Nitrify Ammonia: This is the biochemical oxidation of ammonia nitrogen to the much more stable and benign form called nitrate nitrogen (NO₃-N). The benign NO₃-N can be biologically degraded to nitrogen gas when recycled to the anoxic zone of the WWTP.

Uptake of Phosphorous: The special bacteria (*Acinetobacter*) cultivated in the anaerobic zone absorb a significant amount of phosphorous in the aerobic tank. This absorbed phosphorous is ultimately removed from the water when excess microorganisms are wasted from the WWTP.

6 - The Post Aerobic Anoxic Zone uses the same mechanisms as previously described to convert nitrate to nitrogen gas. This particular zone is simply another location to cultivate special microbes and provide an additional opportunity for these organisms to convert nitrate to nitrogen gas.

7 - The Second Stage Aeration Zone consists of small aerated tanks. This particular zone is simply used to return dissolved oxygen to the water following the anoxic (oxygen free) process.

8 - Secondary Clarification consists of large tanks where the suspended biosolids (microorganisms) are separated from the water, the biosolids simply settle to the bottom of the tank. As a general rule of thumb, approximately 97 to 98% of the biosolids entering the secondary clarifier are recycled back to the anaerobic zone so they can treat incoming waste products. About 2 to 3% of these "phosphorous enriched biosolids" are due to the growth of excess microbes and are wasted to the solids treatment process.

9 - Filtration is a polishing process that removes the trace levels of suspended solids that do not settle in the secondary clarifier. This process employs a layer of sand that removes the solids by straining and absorbing the material.

10 - The Reaeration Process is a small aerated tank used to increase the level of dissolved oxygen in the treated water just before it is discharged. This helps maintain higher oxygen content in the New River in the vicinity of the WWTP's discharge line.

11 - Disinfection is the final process in the WWTP. It is used to kill microorganisms. It is important to note that no chemicals are used in the disinfection process at this WWTP - disinfection is accomplished using environmentally benign ultraviolet (UV) light.

12 - Solids Thickening is used to remove some of the water from the slurry of waste biosolids. Thickening is used to reduce the volume of waste solids and increase the capacity of the WWTP's residuals processing tanks. As a general rule, thickening reduces this volume by about 65 to 75%.

13 - Solids Treatment is used to kill disease causing organisms, reduce odors and for further treatment of the biodegradable pollutants in the biosolids. The process consists of mixed and aerated tanks operated at about 150°F. The heat is generated internally from the biological decomposition of the biosolids by special bacteria that flourish in this type of environment. This process is similar to composting.

Wastewater Collection System:

The MCB Camp Lejeune Wastewater Collection System includes: 193 lift stations, approximately 148 miles of in-service gravity sewer lines and 130 miles of in-service force main lines.

Contacts

For additional copies of this report, more information, or questions concerning the MCB Camp Lejeune Wastewater Treatment System please contact the Director of Utilities for Water and Wastewater at 910-451-7190 ext. 223.

For questions concerning the North Carolina Wastewater Annual Performance Program contact the Water Quality Permitting, Compliance and Expedited Permitting Unit of the NCDEQ, Division of Water Resources, Mr. Michael Montabello at 919-707-3624.

AWWTP Permit Limits and Performance Data

Permit Limits on AWWTP Effluent

Parameter	Monthly Average Limits (mg/L)	
	April 1 to October 31	November 1 to March 31
BOD ₅	5.0	10.0
TSS	30.0	30.0
NH ₃ -N	2.0	4.0
Phosphorous	0.5	1.0
	Daily Maximum Limits (mg/L)	
BOD ₅	7.5	15.0
TSS	45.0	45.0
NH ₃ -N	10.0	20.0

Volume of Wastewater Treated

Daily Average	5.00	million gallons per day
Total Gallons Treated for the Year	1.8	billion gallons

Biosolids Production During 12 Month Period

Gallons of liquid containing	3.11	% solids	4,764,000
Dry Tons (Excluding Water)			626.45

Recently completed improvements and current and future projects include: Sewer force main air release valve location study, hydrogen sulfide remediation at major lift stations, lightning protection installation, Ongoing - water/wastewater Supervisory Control and Data Acquisition system upgrades, Consolidated Drinking Water Plant discharge study, wastewater data management - database, purchased a filter press, warehouse modernization - inventory management, replaced backup diesel bypass pumps at several locations, replaced automatic transfer switches on 3 AWWTP generators, installed debris removal systems at 6 additional lift stations, and recently completed repairs on the effluent sand filters.

AWWTP Overall Performance

Overall operation of the MCB Camp Lejeune AWWTP has met specifications.

Summary of Violations

MCB Camp Lejeune received no Notice of Violation (NOV) for the 12 month period July 2023 - June 2024

Wastewater Collection System - Public Reportable Spills

The North Carolina Clean Water Act of 1999, which became effective October 1, 1999, and as revised on September 20, 2014, requires that wastewater owners or operators must notify the public of wastewater spills. Wastewater owners or operators must issue a press release after a discharge to surface waters of 1,000 gallons or more within 24 hours of first knowledge of the spill by the owner/operator. The press release must be issued to "all print and electronic news media that provide general coverage within the county where the discharge occurred". For inadvertent discharges of wastewater reaching surface waters exceeding 15,000 gallons, a public notice is required in addition to a press release. During the monitoring period of record there were three (3) reportable sewage overflows (spills). A summary of each is listed below:

Reportable Sewage Overflows (Spills)

Date	Estimated Volume (gal)	Surface Water Reached	Location of Spill	Reason For Spill
8/22/2023	12,000	NO	Lift Station TT99	Pump Station turned off for force main repair
8/31/2023	10,000	NO	Lift Station P3TC	Hurricane Idalia
11/5/2023	8,000	YES	Lift Station TT99	Lift Station PLC Failure

Proper Disposal of FOG and Domestic Garbage

FOG

Did you know that cooking grease is the main cause of most residential pipeline and the Base's wastewater collection system blockages? Grease is the leading cause of sewer overflows. NEVER pour grease down any drain. The proper disposal of Fats, Oil, and Grease (FOG) into a trash or garbage container helps prevent wastewater overflows in our community. Sewer backups can cause damage to homes, health hazards, and threaten the environment. Sewer pipes blocked by grease are an increasing cause of overflows.

Cooking grease coats the inside walls of sewer pipes, similar to the way fatty foods can clog your arteries. The grease that clings to the inside of the pipes builds up over time and acts as a host for other materials to cling to, restricting the size of the pipe even more. Eventually the pipe becomes completely clogged and wastewater will backup either in the resident's yard or through a manhole into the street and possibly into waterways.

FOG comes from a wide range of residential, commercial, and industrial sources. Residences, restaurants, school cafeterias, commissaries, and hospitals are all FOG generators. FOG is a natural consequence of cooking - it comes from butter, lard, meats, nuts, vegetable fats and oils, and is found on pots, pans, grills, and deep fat fryers. With the large number of FOG sources on Base, the Camp Lejeune Advanced Wastewater Treatment System can experience increased difficulty with grease clogging pipes and pump stations and affecting wastewater treatment operations at the plant. Sewer backups caused by the accumulation of FOG are completely preventable.

MCB Camp Lejeune prohibits the intentional release of FOG into the wastewater system. Under no conditions should FOG, or FOG components, be poured, scraped, or otherwise disposed of into sinks, toilets, or any other wastewater system component.

Remember, the best way to manage FOG is to keep it out of the system. Here are some helpful tips on making this possible:

1. Dry wipe all cooking supplies and equipment. Use a paper towel or napkin to remove greasy leftovers from pots and dishes prior to washing in the sink or dishwasher. Place leftover foods, fat trimmings from meat, etc. in a trash can. Do not dispose of scrapings in a sink, toilet, floor drain, or any other component of the wastewater system.
2. All cooking oils (including salad oil, cooking oil, bacon grease, butter, and marinades) need to be poured into a container. The container can be an old milk carton, frozen juice container or other recyclable container and disposed of in the garbage.
3. Don't use chemicals to remove grease clogs. Chemicals damage the piping system and just move the problem into a different location further down the collection system.

Following these simple tips will allow Camp Lejeune's Advanced Wastewater Treatment System to function properly, therefore providing a healthy environment for us all.

Household Garbage

Domestic garbage also should not be disposed of in the sanitary sewer system. Sewer pipes and wastewater treatment plant equipment can be damaged by improperly disposed of household items. Do NOT flush baby wipes, even if they say they are "flushable".